

Operating Instructions for the Crusader 3000D Spotter

1. **Filling the Spotter with cleaning solution:**
 - a. Release the front and rear draw latch and lift off the upper recovery tank.
 - b. Add the water and the chemicals to the lower (solution) tank.
 - c. Replace the upper (recovery) tank on top of the lower (solution) tank and latch both the front and rear latches.

2. **To operate the Spotter:**
 - a. Attach the solution hose feed line to the female quick disconnect on the front of the spotter.
 - b. Attach the vacuum hose to the vacuum inlet on the recovery tank at the top of the spotter.
 - c. The switch at the rear of the spotter has three (3) positions. When the switch is placed in the up position both the pump and the vacuum motor will run. When the switch is placed in the center position, the entire unit is turned off. When the switch is placed in the down position, only the pump will run. This switch position (down) is typically used for pre-spraying or spotting the carpet prior to vacuuming up the solution.
 - d. When you turn the pump on, (or the pump and the vacuum on), it takes the pump a few seconds to prime and start spraying. You may have to hold the trigger on the hand tool or the wand for a few seconds before it starts to spray out the solution.
 - e. Be sure you never let the pump run when there is no solution in the tank, as the pump will burn out and this is NOT covered under warranty.

3. **Cleaning the unit and Storage:**
 - a. To empty the recovery tank, first remove the vacuum hose. Then release both the front and rear latches and lift off the top recovery tank.
 - b. Pour out the dirty solution through the vacuum inlet. This is of course after you have removed the vacuum hose from the inlet and the recovery tank from the bottom solution tank.
 - c. When you are finished using the spotter, unscrew the clear plastic access cover on the recovery tank and flush out any residual dirt and allow it to dry out. Also, be sure to empty out any extra solution from the solution tank and allow it to dry out before replacing the recovery tank on the unit and putting it in storage. Be sure to always store the unit and it's accessories in a place where it is above freezing. If the unit and/or hand tool/wands freeze, this could cause damage to the pump and other internal components.

4. **Trouble Shooting:**
 - a. If the pump doesn't spray make sure you have enough solution in the bottom tank to cover the small screen filter. This is the inlet where chemicals flow to the pump so it must be submersed in solution. Also make sure that the solution hose connector is pushed all the way into the female connector on the spotter and that the jet on the hand tool or wand is not plugged.
 - b. Place the switch in the "pump only" position and listen to see if you can hear the pump running.
 - c. Depress the trigger on the hand tool or wand so that the air can be released and the solution is allowed to flow.
 - d. If the vacuum recovery is weak:

- ⇒ Check to make sure the top tank is in the proper position and both draw latches are engaged.
 - ⇒ Check to make sure the ball float shut off inside of the recovery tank is clean.
 - ⇒ Check for blockage in hose and hand tool inlet.
 - ⇒ Check the gasket on the vacuum motor and replace both the gasket and screen if they appear to be worn or missing.
5. **Replacing the pump or vacuum motor:** Simply remove the recovery tank, after you make sure the unit is not plugged into a wall socket. Tip the unit over and remove the six (6) screws that hold on the back cover. You can change out the vacuum motor by simply removing the two (2) screws holding it onto the motor plate. If you need to change the pump remove the two (2) screws holding the front plate in place, and loosen the clamp holding the hose onto the hose barb coming out of the tank. After you change out the pump and reconnect the hoses, set the front cover in place, (do not put in the front two (2) screws yet). Set the back cover in place and insert the ¾” screw with the spaces between the 2 (two) covers in the center underneath where the two (2) covers overlap. Start these two (2) screws first, and then put the four (4) screws in the back along with the two (2) screws in the front. Then tighten all eight (8) screws securely. If you start the two (2) screws underneath with the spacers first, the unit will go back together easily.

Industrial Product Limited Warranty

The Crusader spotter is warranted to be free of defects in material and workmanship under normal use, for a period of one (1) year from the date of manufacture.

The limited warranty will not apply to pumps/products that were improperly installed, misapplied, damaged, altered, or are incompatible with fluids.

All industrial pumps/products must be flushed of any chemicals before shipping.

Returns are to be shipped postage prepaid to Crusader Mfg. Inc. Crusader shall not be liable for freight damage incurred during shipping. Package returns carefully.

Crusader's obligation under this warranty policy is limited to the repair or replacement of the pump/product. All returns will be tested per Crusader factory criteria.

No credit or labor allowances will be given for pumps or products returned as defective. Warranty replacement will be shipped on a freight allowed basis.

This limited warranty is in lieu of all other warranties, expressed or implied, and no other person is authorized to give any other warranty or assume obligation or liability on Crusader's behalf. Crusader shall not be liable for any labor, damage, or other expense, nor shall Crusader be liable for any indirect, incidental, or consequential damages of any kind incurred by the reason of the use or sale of any defective product or part. This limited warranty covers industrial products distributed within the United States of American and Canada.

Crusader Mfg. Inc.
2955 Lone Oak Circle, #8
Eagan, MN 55121
800-597-3336
(Fax) 800-998-7311
sales@crusadermfg.com

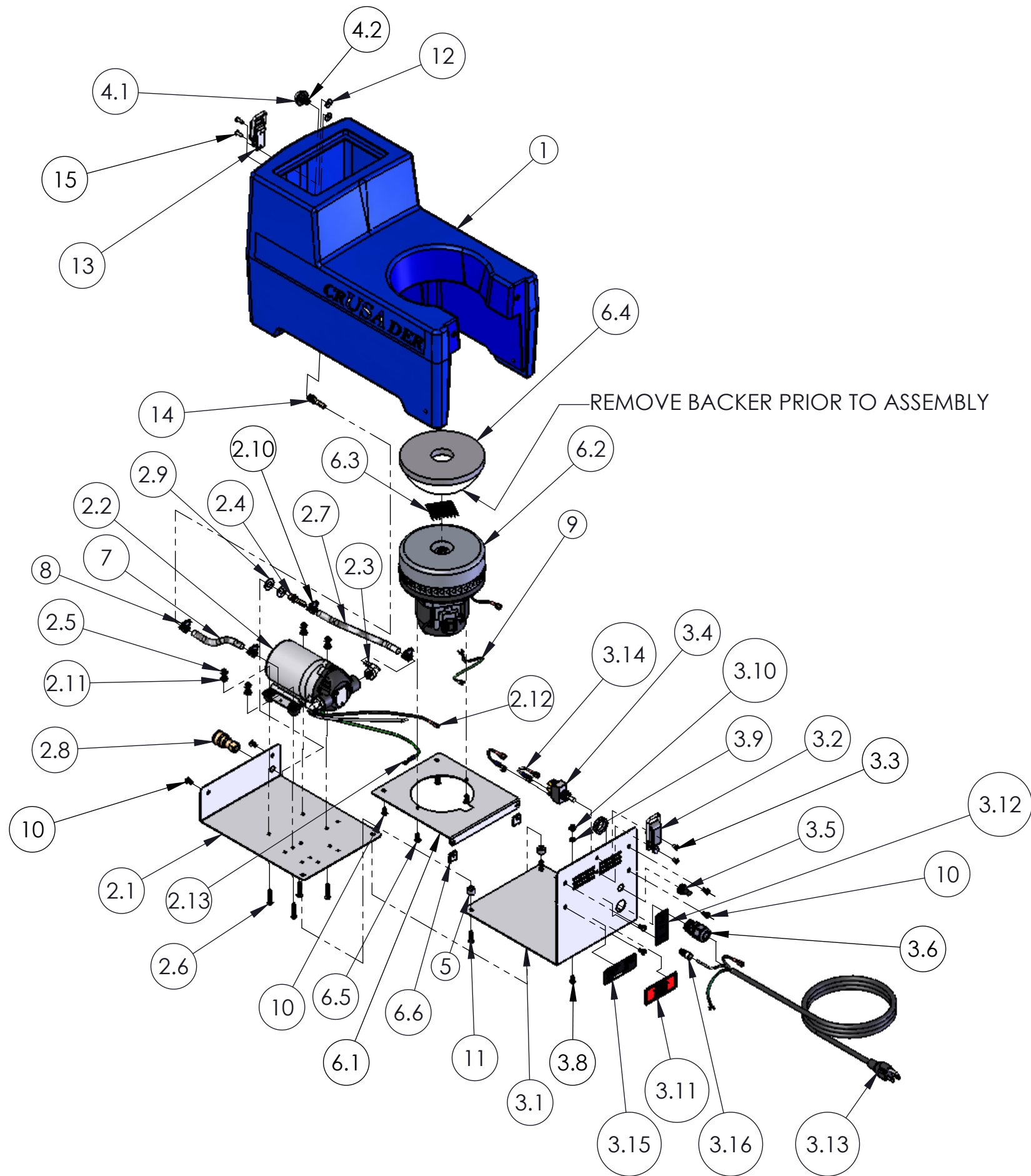

ITEM NO.	QTY.	UM	PART NUMBER	DESCRIPTION
1	1	EA	2900	SOLUTION TANK
2	1	EA	60 PSI PUMP GROUP	
2.1	1	EA	2902	FRONT PANEL
2.2	1	EA	2950	60 PSI PUMP
2.3	2	EA	2917	3/8" MPT X 1/4" RT ANGLE HOSE BARB
2.4	1	EA	2460	1/8" MPT X 1/4" STRAIGHT HOSE BARB
2.5	4	EA	1009	#10 NYLOK NUT
2.6	4	EA	1010	#10-24 X 1" SS PHMS
2.7	1	EA	2919A	1/4" X 8-1/2" HOSE
2.8	1	EA	2469	1/8" FEMALE COUPLER
2.9	2	EA	1061	3/8" WASHER
2.10	2	EA	2915	#16 HOSE CLAMP
2.11	4	EA	1002	3/16" WASHER FOR RIVET
2.12	1	EA	1014	CRIMP TERMINAL
2.13	1	EA	1015	RING GROUND TERMINAL
3	1	EA	REAR PANEL GROUP	
3.1	1	EA	2903-1	REAR PANEL
3.2	1	EA	2906	LATCH
3.3	2	EA	1001A	RIVET - OPEN END
3.4	1	EA	2920	3 POSITION SWITCH
3.5	1	EA	2922	SWITCH BOOT
3.6	1	EA	2428	STRAIN RELIEF AND NUT
3.8	1	EA	1023	#10-24 X 3/8" SS PHMS
3.9	1	EA	1039	GROUND WASHER
3.10	1	EA	1009	#10 NYLOK NUT
3.11	1	EA	2035	WARNING DECAL
3.12	1	EA	2921	SWITCH DECAL
3.13	1	EA	2144	25' POWER CORD
3.14	2	EA	1074A	3" JUMPER W/ TERMINALS
3.15	1	EA	2451	NAMEPLATE
3.16	1	EA	1029	ORANGE WIRE NUT
4.1	1	EA	2908	SMALL SUCTION SCREEN
4.2	1	EA	2916	1/8" MPT NIPPLE
5	2	EA	1034	3/8" SPACER
6	1	EA	MOTOR GROUP - 105 INCH	
6.1	1	EA	2904 B	MOTOR PLATE
6.2	1	EA	2051	105" WATER LIFT MOTOR
6.3	1	EA	1043A	MOTOR SCREEN
6.4	1	EA	2453	MOTOR GASKET W/ PSA
6.5	2	EA	1012	#10 X 1/2" PHSMFPH-TYPE A
6.6	2	EA	1006	TINNERMAN SPEED NUT
7	1	EA	2918A	1/4" X 5" HOSE
8	2	EA	2915	#16 HOSE CLAMP
9	1	EA	1041	GROUND LEAD
10	8	EA	1023	#10-24 X 3/8" SS PHMS
11	2	EA	1021	#10-24 X 3/4" SS PHMS
12	2	EA	1002	3/16" WASHER FOR RIVET
13	1	EA	2906	LATCH
14	1	EA	2460	1/8" MPT X 1/4" STRAIGHT HOSE BARB
15	2	EA	1001	RIVET - CLOSED END

MATERIAL:		REV	DATE	BY	REVISION	
FINISH:		UNLESS OTHERWISE SPECIFIED TOLERANCES ARE:			CRUSADER MANUFACTURING CORP.	
<p>THIRD ANGLE PROJECTION</p>		FRACTION ± 1/32			2955 LONE OAK CIRCLE #8, EAGAN., MN 55121	
		ANGLE ± 1°			TELEPHONE: 651-456-9100 FAX: 651-456-9191	
PROPRIETARY AND CONFIDENTIAL		.X ± .02			TITLE SOLUTION TANK ASSEMBLY	
THE INFORMATION CONTAINED IN THIS DRAWING IS THE SOLE PROPERTY OF CRUSADER MANUFACTURING CORP. ANY REPRODUCTION IN PART OR AS A WHOLE WITHOUT THE WRITTEN PERMISSION OF CRUSADER MANUFACTURING CORP. IS PROHIBITED.		.XX ± .01			SIZE B	
		.XXX ± .005			NAME 3000D SOLUTION TANK ASSY	
		ALL DIMENSIONS IN INCHES UNLESS NOTED			REV -	
		NAME	DATE	SCALE	DO NOT SCALE DRAWING	
		DRAWN	DH	11-17-07	SHEET 2 OF 2	
		APPR.				

3000D Spotter Wiring Diagram

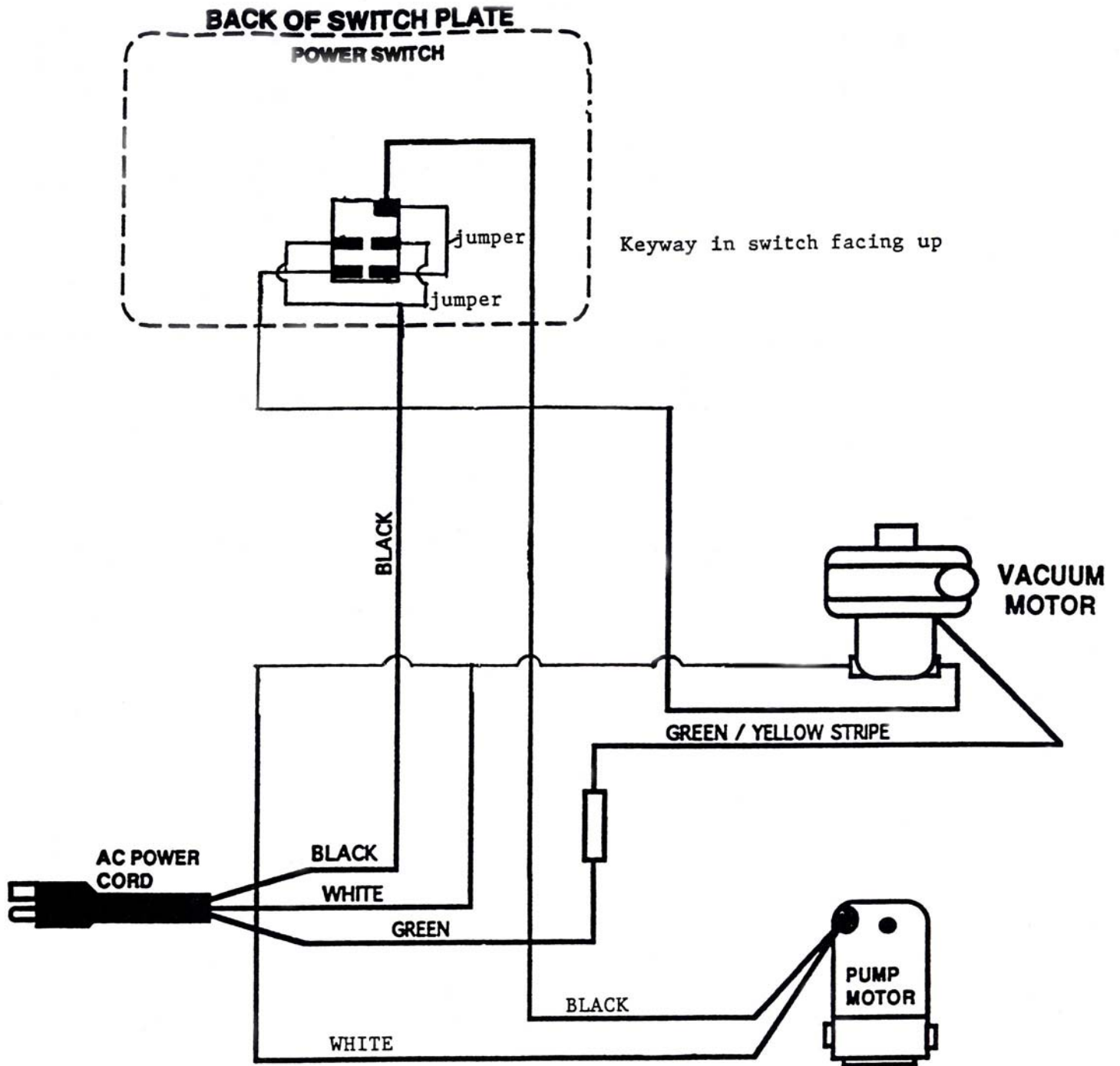

Property of:
Crusader Mfg., Inc.
2955 Lone Oak Circle, #8
Eagan, MN 55121

800-597-3336

www.crusadermfg.com

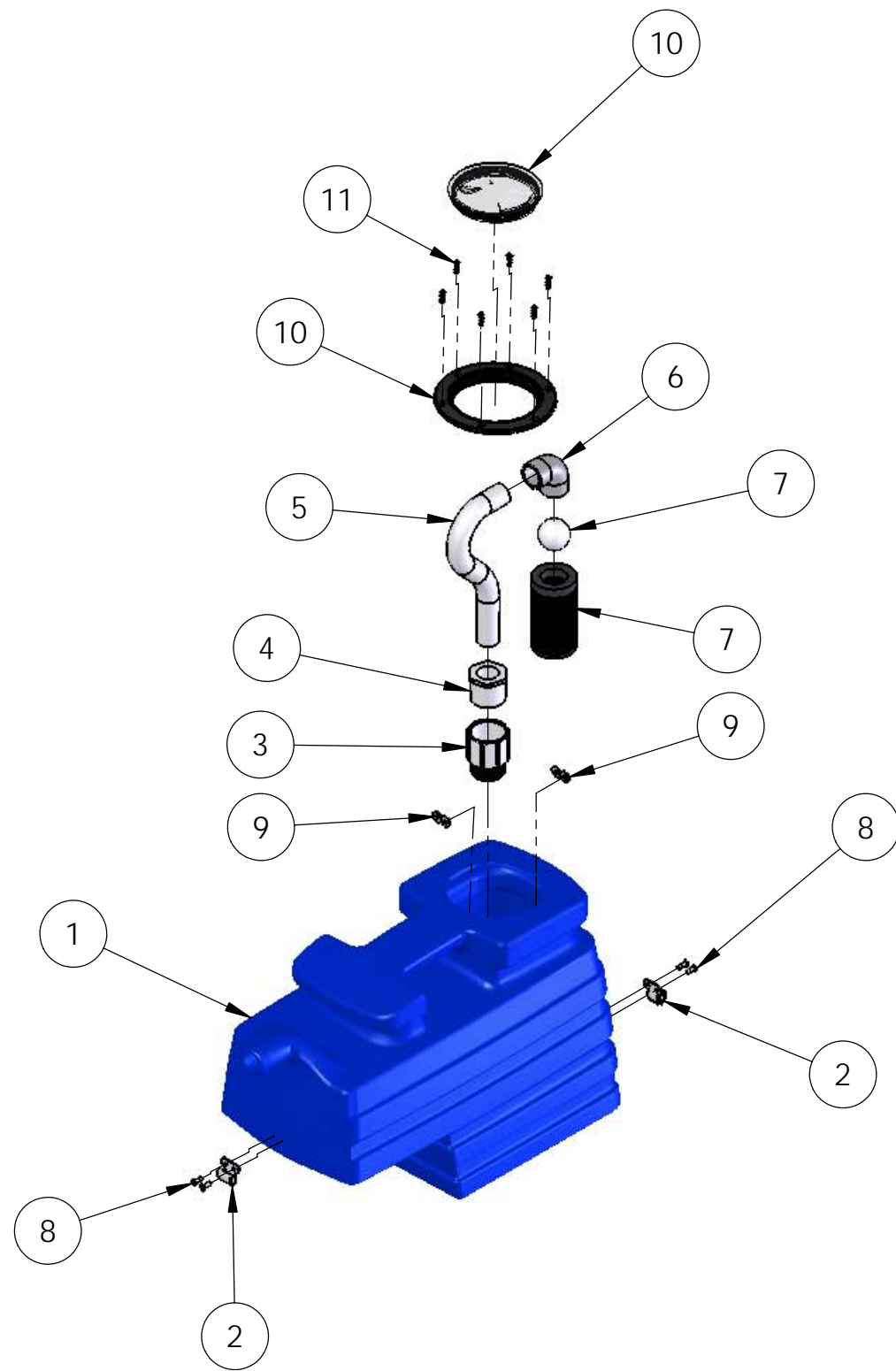

ITEM NO.	QTY.	UM	PART NUMBER	DESCRIPTION
1	1	EA	2901	RECOVERY TANK
2	2	EA	2907	STRIKE FOR THE LATCH
3	1	EA	2912	1 1/4" MPT FITTING
4	1	EA	2913	1 1/4" TO 3/4" REDUCER
5	1	EA	2911	3/4" STAND PIPE
6	1	EA	2914	3/4" RIGHT ANGLE ELBOW
7	1	EA	2909	BALL FLOAT SHUTOFF
8	4	EA	1001	RIVET - CLOSED END
9	4	EA	1002	3/16" WASHER FOR RIVET
10	1	EA	2910	PORT HOLE COVER ASSY
11	6	EA	1070	#8 X 3/4" COUNTERSINK SCREW

MATERIAL:		REV	DATE	BY	REVISION	
FINISH:		UNLESS OTHERWISE SPECIFIED TOLERANCES ARE:			CRUSADER MANUFACTURING CORP.	
<p>THIRD ANGLE PROJECTION</p>		FRACTION ± 1/32			2955 LONE OAK CIRCLE #8, EAGAN, MN 55121	
		ANGLE ± 1°			TELEPHONE: 651-456-9100 FAX: 651-456-9191	
PROPRIETARY AND CONFIDENTIAL		X ± .02			TITLE RECOVERY TANK ASSEMBLY	
THE INFORMATION CONTAINED IN THIS DRAWING IS THE SOLE PROPERTY OF CRUSADER MANUFACTURING CORP. ANY REPRODUCTION IN PART OR AS A WHOLE WITHOUT THE WRITTEN PERMISSION OF CRUSADER MANUFACTURING CORP. IS PROHIBITED.		XX ± .01			SIZE B	
		XXX ± .005			NAME RECOVERY TANK ASSEMBLY	
		ALL DIMENSIONS IN INCHES UNLESS NOTED			REV -	
		NAME	DATE	SCALE 1:4		
		DRAWN DH	2-11-07	DO NOT SCALE DRAWING		
		APPR.		SHEET 2 OF 2		