

## H.E.P.A. Dry Vacuums

The Crusader **critical filter vacuums** offer you a filter retention efficiency of 99.97% at .3 micron particle size. All models feature a multiple stage filtration process to protect the (H.E.P.A.) filter from premature failure. All of our H.E.P.A. critical filters are individually DOP tested and certified to safely filter dry hazardous materials. The vacuums are available in several different tank capacities with several different motor options.

### Features

- 5 Stage filtration
- 10, 15, and 30 gallon polyethylene tank options as well as a 55 gallon drum adapter option
- Chrome plated steel head
- 8" Non-marking wheels & 3" swivel casters on 10 & 15 gallon units. Grey non-marking wheels are available on the 30 gallon
- Transport handle is standard on the 15 and 30 gallon, and is optional 10 gallon
- Easy to clean low profile design
- 1 1/2" 10' hose comes standard with each vacuum
- Premium series comes standard with a 35' cord, and can be upgraded to a 50' cord
- Utility series comes standard with a 25' cord, and can be upgraded to a 35' or 50' cord

We have a large assortment of tools, attachments, and hoses available. Please see our vacuum tools and accessories literature or our website for more information.



10 gallon Premium Series H.E.P.A. Vacuum shown above. Also available in the Utility Series.



15 gallon Utility Series H.E.P.A. Vacuum shown above. Also available in the Premium Series.



30 Gallon Utility Series H.E.P.A. shown above.



Utility Series H.E.P.A. 55 gallon drum adapter with optional #8055-CART 55 gallon cart shown above.

(55 gallon drum not included)

### Crusader Mfg., Inc.

2955 Lone Oak Circle, #8  
Eagan, MN 55121

(651) 456-9100 • Fax: (651) 456-9191  
(800) 597-3336 • Fax: (800) 998-7311

E-mail: sales@crusadermfg.com

**www.crusadermfg.com**

*Distributed by*



# H.E.P.A. dry vacuums specifications and available accessories

## Premium series specifications:

Model (Tank Size in Gallons)	H085(10),(15)	H105(10),(15)	H130(10),(15)
Airflow	95 CFM	112 CFM	100 CFM
Dry Tank Capacity in Bushels	(1), (1.5)	(1), (1.5)	(1), (1.5)
H.E.P.A. Filter Area	2520 PSI	2520 PSI	2520 PSI
Filtered Particle	0.3 Microns	0.3 Microns	0.3 Microns
Horsepower	1	2	2.3
Motor	2 stage bypass	2 stage bypass	3 stage bypass
Power	115 v 60 Hz	115 v 60 Hz	115v 60 Hz
Amperage Draw	8 amps	11.7 amps	12.8 amps
Standard Power Cord	35' 16/3	35' 16/3	35' 16/3
Machine Weight	(45), (43) Lbs.	(46), (55) Lbs.	(47), (56) Lbs.

All models come with the Crusader Standard Warranty

## Utility series specifications:

Model (Tank Size in Gallons)	MH850(10),(15),(30),(55)	MH1050(10),(15),(30),(55)	MH1300(10),(15),(30),(55)
Airflow	95 CFM	112 CFM	100 CFM
Dry Tank Capacity in Bushels	(1), (1.5), (3), (5.5)	(1), (1.5), (3), (5.5)	(1), (1.5), (3), (5.5)
H.E.P.A. Filter Area	2520 PSI	2520 PSI	2520 PSI
Filtered Particle	0.3 Microns	0.3 Microns	0.3 Microns
Horsepower	1	2	2.3
Motor	2 stage bypass	2 stage bypass	3 stage bypass
Power	115 v 60 Hz	115 v 60 Hz	115v 60 Hz
Amperage Draw	8 amps	11.7 amps	12.8 amps
Standard Power Cord	25' 16/3	25' 16/3	25' 16/3
Machine Weight	(43), (52), (94), (33) Lbs.	(44), (53), (95), (35) Lbs.	(45), (54), (96), (38) Lbs.

All models come with the Crusader Standard Warranty

5 STAGE FILTER SYSTEM

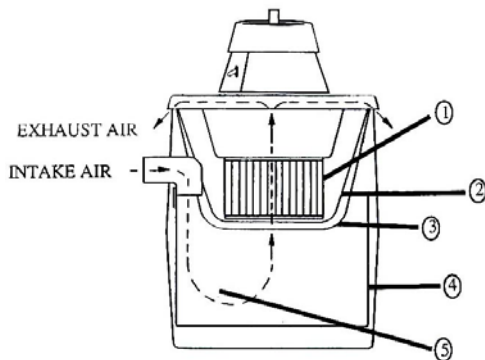

### #4030 H.E.P.A. Filter Specifications

**Efficiency:** 99.97 At .3 Micron (H.E.P.A.)

**Construction:** End Cap—Molded Plastisol, Inner & Outer Liner—Expanded Galvanized Steel, Filter Media—Microglass Fiber & Cellulose

**Applications:** For collection of Toxic Hazardous Waste Material such as Asbestos, Silica, Lead, Mercury and other health endangering dusts.

### Part Identification

<u>Part Identification</u>	<u>Part #</u>
1. H.E.P.A. Filter	#4030
2. Coated Cloth Filter	#4049
3. Disposable Filter Protector	#4031
4. Disposable Collector Bag	#4013
5. Plastic Liner	#4032