

Model 8055-CART 55 Gallon Cart

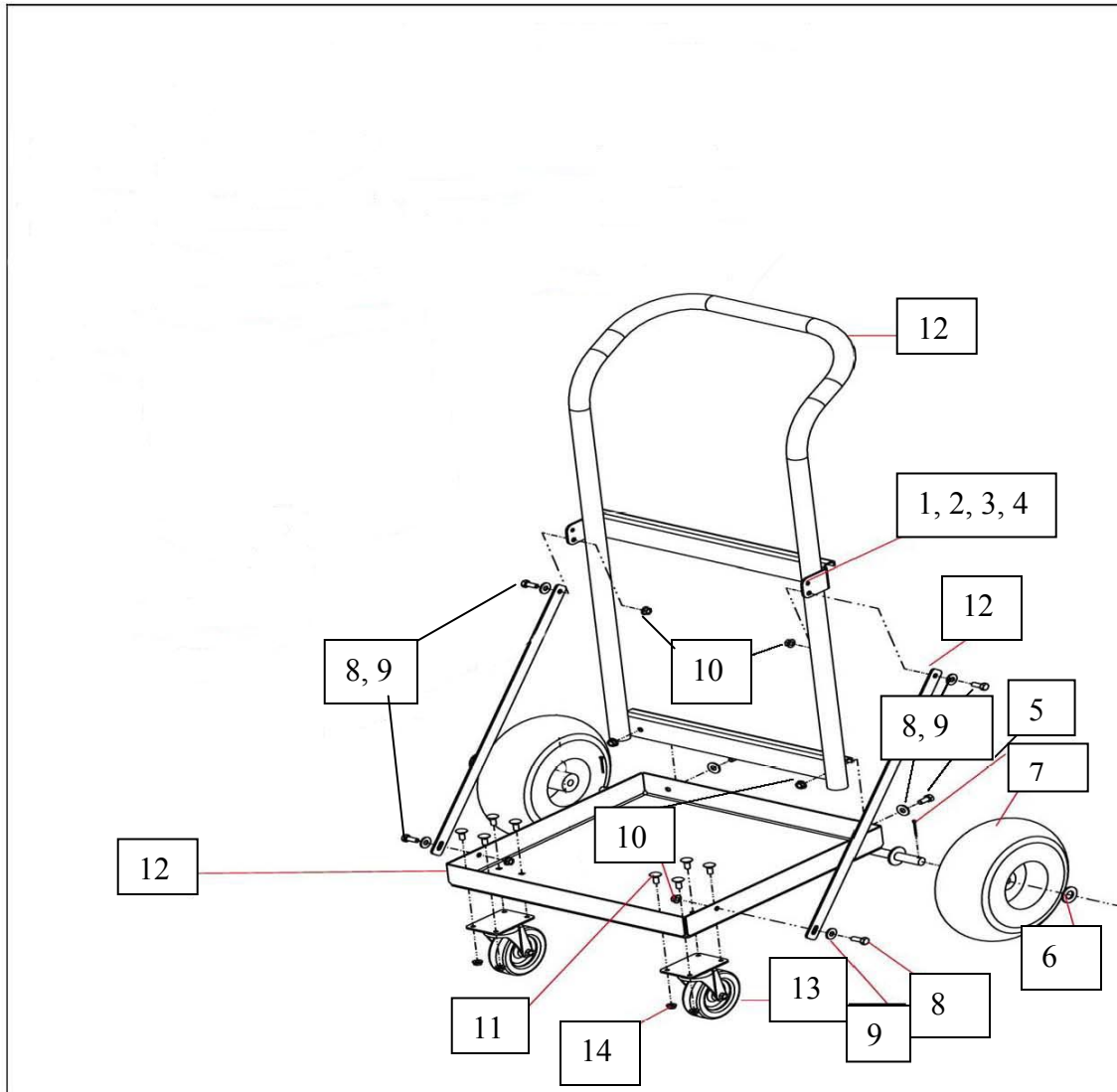

<b>Item</b>	<b>Qty.</b>	<b>Part #</b>	<b>Description</b>
1.	1	2327	Ratchet Strap Assembly (Not Shown)
2.	1	1052A	5/16" -18 Bolt (Not Shown)
3.	1	1054A	5/16" Flat Washer (Not Shown)
4.	1	1019A	5/16"- 18 Nylok Nut (Not Shown)
5.	2	1026	Cotter Pin
6.	2	1062A	5/8" Washer
7.	2	2001B	10" Pneumatic Wheel (NOTE: Grease axle before assembling)
8.	6	1052A	5/16"-18 Bolt
9.	6	1054A	5/16" Flat Washer
10.	6	1019A	5/16"-18 Nylok Nut
11.	8	1004A	¼" Carriage Bolt
12.	1	R8055-CART	Fabricated 55 Gallon Vac Cart
13.	2	2002B	Bolt On 4" Caster (NOTE: Install w/grease zerk towards front of cart & grease)
14.	8	1019	¼" - 20 Nylok Nut

Tools needed to assemble:

- 1 – Pliers
- 2- 7/16" Wrenches
- 2- 1/2" Wrenches

**IMPORTANT NOTES:**

1. Grease the axle on both sides of the cart base before putting the 10" Pneumatic wheels on. Item 13 on the schematic.
2. While installing both of the front casters be sure the grease zerk faces the front of the cart. After you install both casters, be sure to grease them with a standard grease gun. Item 19 on the schematic.

Crusader Mfg. Inc. ■ 2955 Lone Oak Circle, #8 ■ Eagan, MN 55121 ■ (800) 597-3336  
[www.crusadermfg.com](http://www.crusadermfg.com) ■ Sales@crusadermfg.com

Revised 02-27-2007